

# Atlas Meridian Gazebo

## (All Sizes)



## Component List

Component	Dimensions	Gazebo Size			Part
		1800mm x 1800mm	2400mm x 2400mm	3000mm x 3000mm	
4 x Pergola Corner Posts	(92mm x 92mm)	2100mm			(A)
2 x Roof Frame (Front / Rear)	(95mm x 44mm)	1800mm	2400mm	3000mm	(B)
2 x Roof Frame (Sides)	(95mm x 44mm)	1712mm	2312mm	2912mm	(C)
1 x Roof Frame (Apex Beam)	(95mm x 44mm)	1800mm	2400mm	3000mm	(D)
2 x King Post (Front / Rear)	(95mm x 44mm)	550mm - Notched			(E)
Roof Rafters - Angle Cut	(70mm x 44mm)	8 @ 1006mm	10 @ 1350mm	12 @ 1605mm	(F)
Corner Support Braces	(92mm x 42mm)	2 @ 470mm	8 @ 470mm	8 @ 470mm	(G)
Featheredge Roof Boarding	(12mm x 125mm)	22 @ 1800mm	26 @ 2400mm	34 @ 3000mm	(H)
1 x Roof Capping	(21mm x 100mm)	1800mm	2400mm	3000mm	(I)
3 x Side / Rear Railing Kits		1800mm	2400mm	3000mm	(J)
1 x Decorative Finial	(120mm x 120mm)				(K)
50mm Coated Green Screws		88	130	204	(FIX 1)
75mm Coated Green Screws		28	28	28	(FIX 2)
100mm Wood Screws		16	20	24	(FIX 3)

### Tools Required

Drill Driver

PZ2 Driver Bit

Pilot Drill Bit

Saw

Pencil

Tape Measure

Spirit Level

A minimum of two people are required to assemble this gazebo.

# Atlas Meridian Gazebo (All Sizes)

**Kennings**

## Step 1

*\*To prevent splits, drill a pilot hole before driving screws\**

### Primary Frame Assembly

In this initial stage, you will construct the two main side frames of the gazebo. Accuracy here ensures the structural integrity of the entire build.

#### Components & Hardware Required

Corner Posts (A), Roof Frame - Sides (C), 75mm Coated Green Screws (FIX 2)

**Positioning:** Lay 2 x Corner Posts (A) on a flat, level surface. Orient the posts so that the notched "upstanding" sections are facing inward toward each other; these notches define the internal corners of your gazebo.

**Alignment:** Place the Roof Framing Timber (C) into the seat of the notches. Ensure the timber sits perfectly flush against the upstanding notched piece of the post.

**Securing the Joint:** Once aligned, fix the timber to the post using two 75mm Coated Green Screws (FIX 2) at each joint. Drive the screws through the framing timber and into the post, ensuring the heads are countersunk or flush with the wood surface.

**Repeat:** Follow the same process for the remaining two posts and the second roof framing timber to create the opposite side frame.

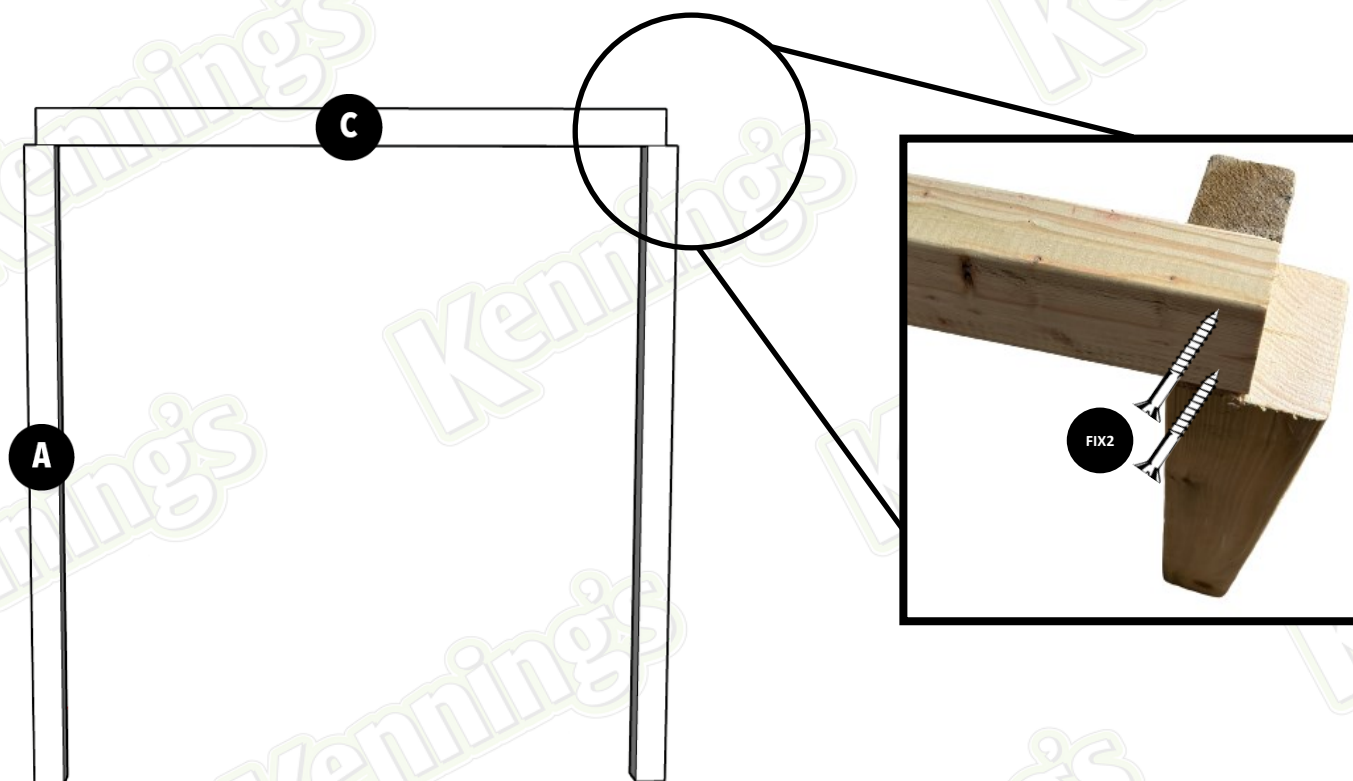

All images are for illustration only. Please see individual item listings for actual item specifications.

Page 2 of 14

# Atlas Meridian Gazebo

## (All Sizes)

**Kennings**

## Step 2

*\*To prevent splits, drill a pilot hole before driving screws\**

### Connecting the Side Frames

In this step, you will join the two assemblies created in Step 1 to form the full perimeter of the gazebo.

### Components & Hardware Required

Roof Frame - Front/Rear (**B**), 75mm Green Coated Screws (**FIX 2**)

**Positioning:** Stand the two frame sections from Step 1 upright, facing each other at the specified width of your gazebo.

**Bridging the Frames:** Place the Connecting Roof Timbers (**B**) between the two side frames. As shown in below diagram, these timbers bridge the gap to complete the roof perimeter.

**Flush Alignment:** Ensure the timber sits flush with the outer cross-section and the top of Posts (**A**). At the rear joints, the roof frame timber should be perfectly level with the existing framing to create a seamless corner.

**Securing:** Fix each end of the Roof Frame (**B**) using two 75mm Coated Green Screws (**FIX 2**) at every point of contact. Drive the screws through the face of the timber into the post/frame assembly as illustrated in the diagram below.

**Note:** To prevent the wood from splitting, it is recommended to drill a small pilot hole before driving the FIX 2 screws, especially near the ends of the timber.



All images are for illustration only. Please see individual item listings for actual item specifications.

Page 3 of 14

# Atlas Meridian Gazebo (All Sizes)

# Kennings's

## Step 3

*\*To prevent splits, drill a pilot hole before driving screws\**

### Side Handrail & Spindle Assembly

In this step, you will join the two assemblies created in Step 1 to form the full perimeter of the gazebo by attaching the three sidings / handrails.

#### IMPORTANT: Pre-Assembly Cutting Guide

The handrails and baserails in your kit are supplied in standard master lengths (1800mm, 2400mm, or 3000mm depending on your model size) and must be trimmed to fit your specific gazebo frame before assembly. To ensure the glass panels remain perfectly centred and evenly distributed across the finished panel, you must cut an equal amount from both ends of the timber.

**The Math:** To account for the width of the main vertical posts, the overall clear distance between your posts is exactly 184mm shorter than the master kit size.

**The Action:** Measure and trim exactly 92mm off EACH end of the Hand/Baserails before attaching the mounting brackets.

**Example:** If your kit includes 1800mm rails, cutting 92mm from the left side and 92mm from the right side will leave you with a final, perfectly centred rail length of 1616mm. Double-check the distance between your installed posts with a tape measure before cutting.

#### Components & Hardware Required

Side / Rear Railing Kits (1 per side) (J) - Hand/Baserails(2 per side), Spindles, Handrail Brackets (4 per side), Bracket Screws

#### Phase 1: Bracket Preparation

**Attach Brackets:** Secure the Handrail Brackets to both ends of all four Hand/Baserails.

**Alignment:** Drive the provided Bracket Screws through the centre-back hole of each bracket and directly into the end of the timber.

**Important:** Ensure the curved top of the bracket is aligned so it faces the same direction as the pre-drilled spindle holes on the rail face.

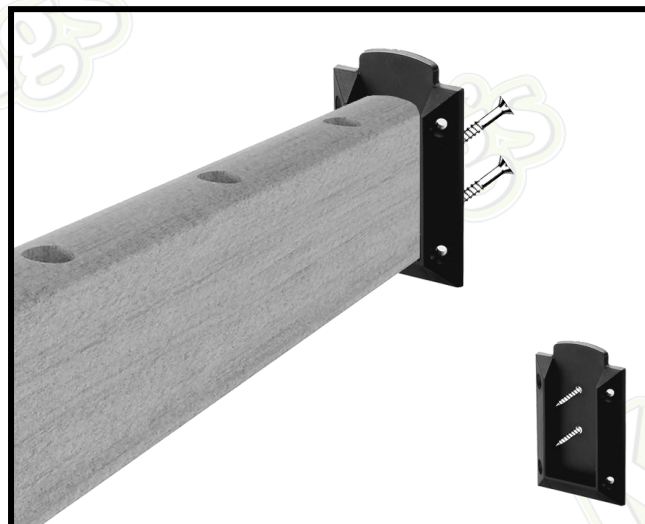

All images are for illustration only. Please see individual item listings for actual item specifications.

Page 4 of 14

## Step 3

*\*To prevent splits, drill a pilot hole before driving screws\**

### Phase 2: Building the Rail Section

**Install the Baserail:** Position one prepared rail, acting as the baserail, horizontally between two of the side posts. Adjust the rail so it is perfectly level and sits at your desired height from the ground.

**Secure to Posts:** Drive the remaining Bracket Screws through the outer holes of the brackets and directly into the posts to lock the baserail in place.

**Insert Spindles:** Slot the spindles vertically into the pre-drilled holes of the secured baserail.

**Optional:** For maximum durability and to prevent any future rattling, apply a small drop of high-quality wood adhesive (such as GB Pro) into each pre-drilled hole before inserting the spindles.

**Cap with Handrail:** Place a second Handrail on top of the vertical spindles, carefully aligning the pre-drilled holes with the tops of the spindles to lock the "ladder" section together. Secure the top brackets to the posts using the supplied screws.

**Repeat:** Follow the exact same process for the opposite side of the gazebo as well as the rear section.

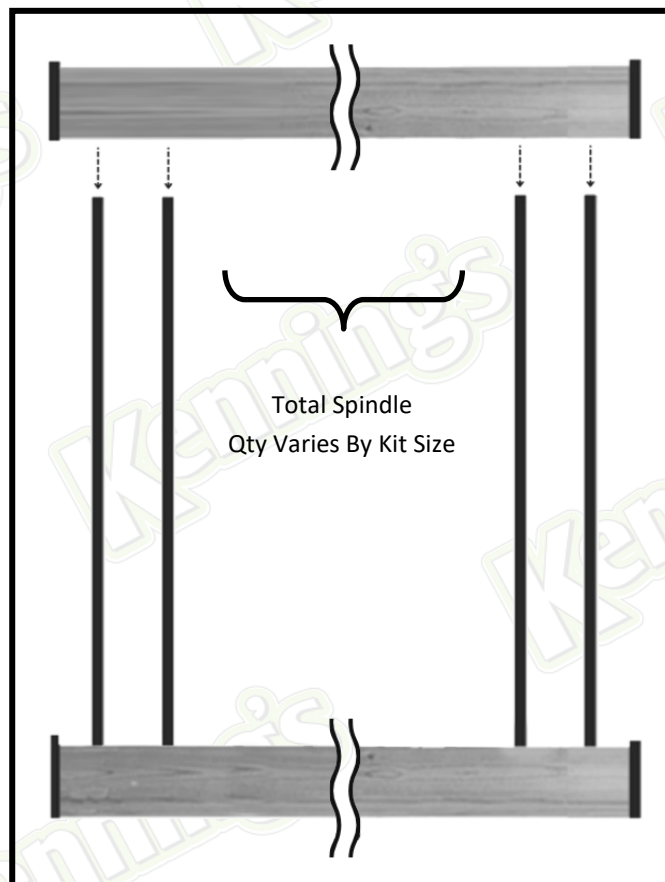

# Atlas Meridian Gazebo (All Sizes)

**Kennings**

*\*To prevent splits, drill a pilot hole before driving screws\**

**PLEASE NOTE:** While the handrails can be installed at any height to suit your personal preference, we recommend a baseline height of **1100mm** from the ground to the top of the handrail for optimal safety and aesthetics.

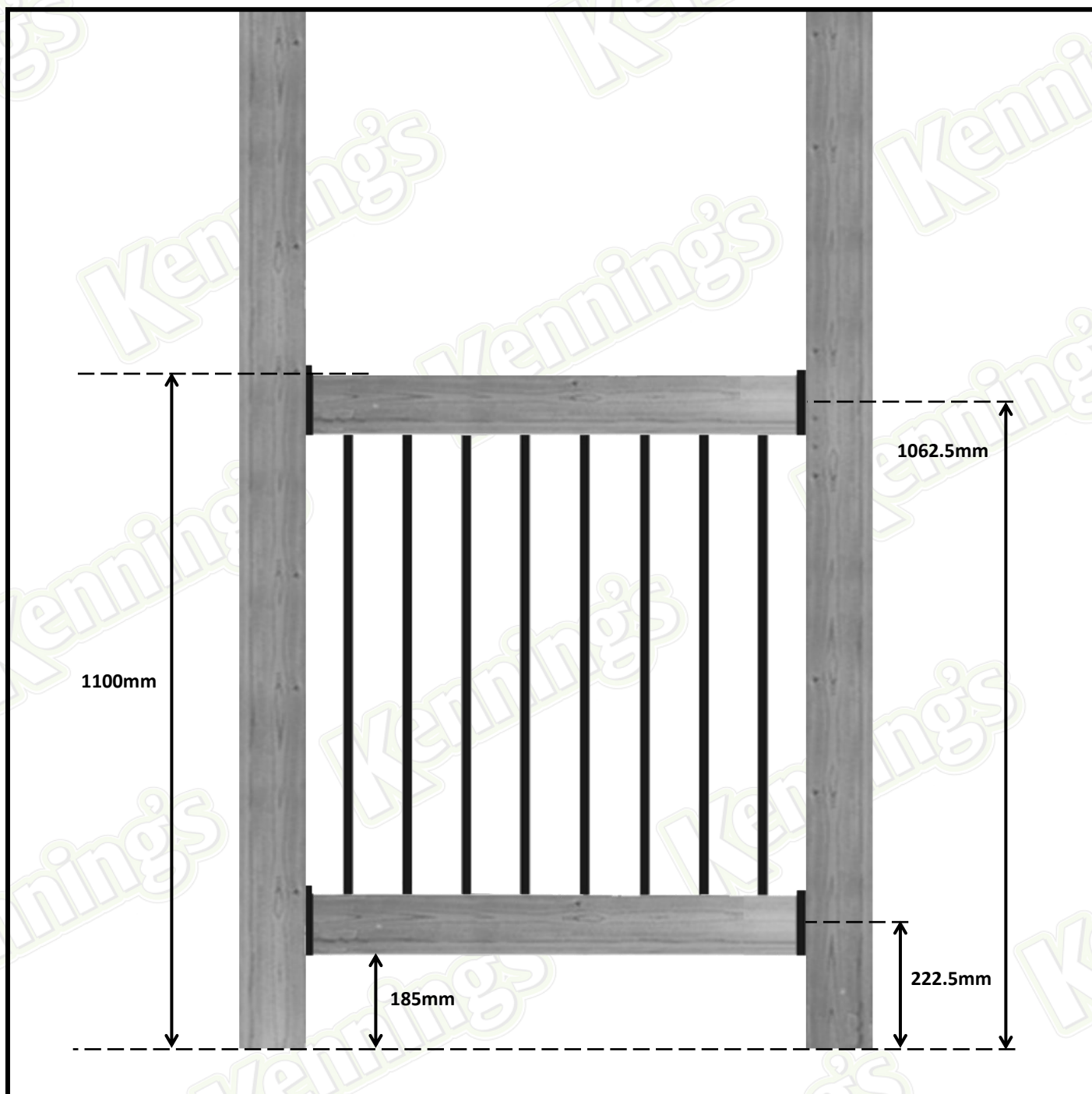

All images are for illustration only. Please see individual item listings for actual item specifications.

Page 6 of 14

# Atlas Meridian Gazebo (All Sizes)

**Kennings**

## Step 4

*\*To prevent splits, drill a pilot hole before driving screws\**

### Front Corner Bracing

To ensure the gazebo is stable and resistant to lateral movement, you will now install the corner braces. These components provide essential structural rigidity to the front of the frame.

### Components & Hardware Required

Corner Braces (**G**), 75mm Coated Green Screws (**FIX 2**)

**Placement:** Position a Corner Brace (**G**) at one of the front corners where the post meets the roof frame. The angled ends of the brace should sit flush against both the vertical post and the horizontal framing timber.

**Securing the Top:** Using one 75mm Wood Screw (**FIX 2**), drive the screw through the pre-angled face of the brace upward into the roof framing timber.

**Securing the Bottom:** Use a second 75mm Wood Screw (**FIX 2**) to secure the lower end of the brace into the vertical post. As shown in the diagram below, the screws should be driven at an angle to ensure a deep, secure bite into the primary timbers.

**Repeat:** Follow the same process for the second front corner to complete the bracing. On the 2400mm and 3000mm versions we have included enough braces to secure all four corners to give additional stability and rigidity which are to be installed in the same way.

**Important:** Because (**FIX 2**) screws are 75mm in length, it is highly recommended to pre-drill pilot holes to guide the screws and prevent the timber from splitting. Ensure the brace is held firmly in position while fastening to maintain a tight, professional looking joint.



All images are for illustration only. Please see individual item listings for actual item specifications.

Page 7 of 14

# Atlas Meridian Gazebo

## (All Sizes)

**Kennings**

### Step 5

*\*To prevent splits, drill a pilot hole before driving screws\**

#### Installing the King Posts

This step marks the beginning of the roof construction. You will establish the central roofline by installing the two vertical king posts and the main apex beam.

#### Components & Hardware Required

King Posts (**E**), 75mm Coated Green Screws (**FIX 2**)

**Find the Centre:** Measure and mark the exact centre point along the top face of the front and rear horizontal roof framing timbers. **Note:** Depending on your specific kit size, this central measurement will be 900mm, 1200mm, or 1500mm.

**Positioning and Fixing:** Place a King Post (**E**) onto your centre mark. Ensure that the back edge of the post sits perfectly flush with the inside face of the framing timber. Secure the post by driving two 75mm Coated Green Screws (**FIX2**) diagonally (toe-screwing) through the lower sides of the upright and deep into the framing timber below.

**Repeat:** Follow the exact same process to install the second King Post (**E**) on the opposite side of the frame.

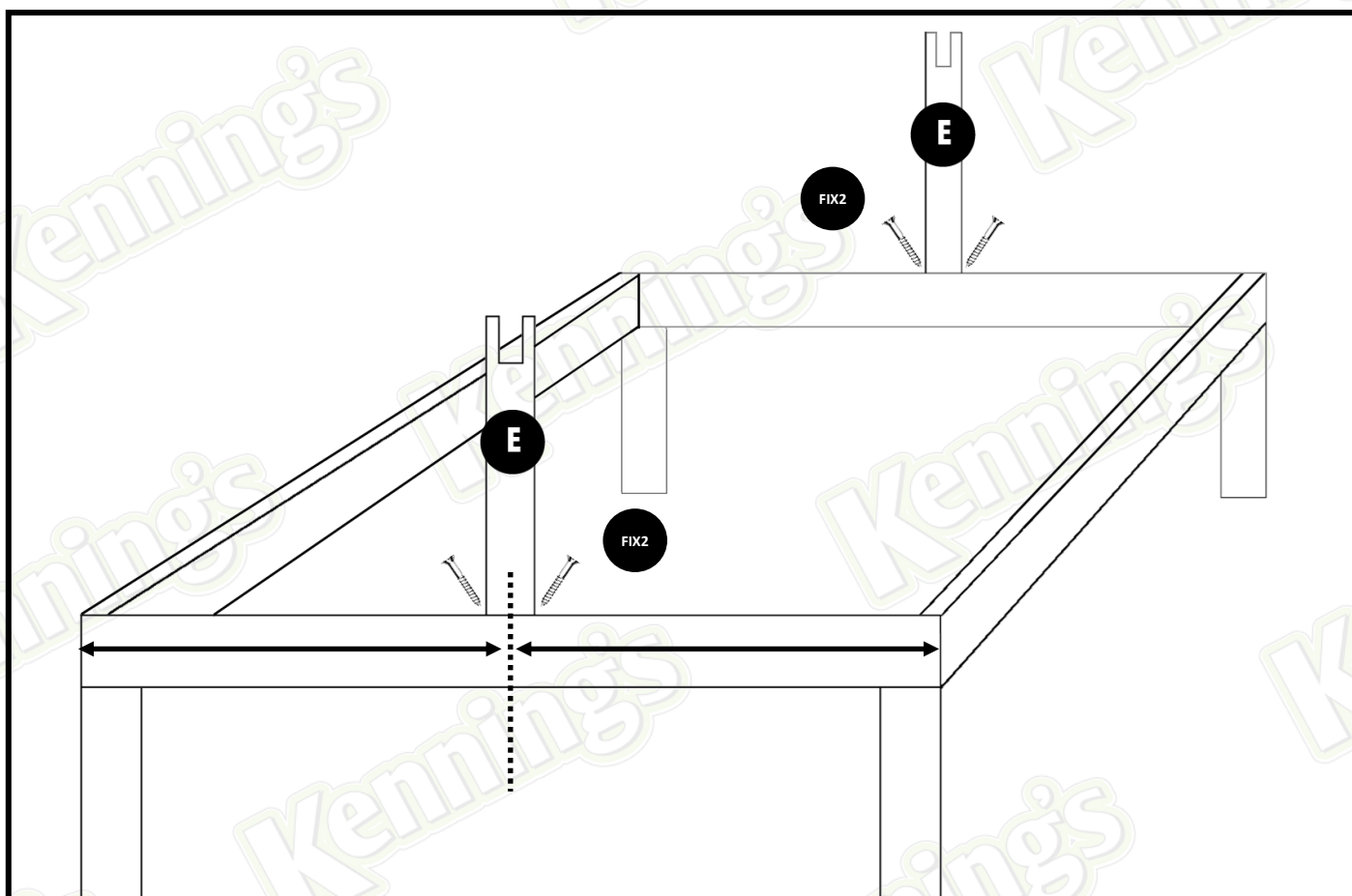

All images are for illustration only. Please see individual item listings for actual item specifications.

Page 8 of 14

# Atlas Meridian Gazebo (All Sizes)

**Kennings**

## Step 6

*\*To prevent splits, drill a pilot hole before driving screws\**

### Mounting the Apex Ridge Beam

#### Components & Hardware Required

Apex Ridge Beam (D), 75mm Coated Green Screws (FIX 2)

**Alignment:** Slot the Apex Ridge Beam (D) into the central notches at the top of both King Posts. The beam should sit perfectly level, with its ends completely flush with the front and back faces of the posts as shown below.

**Staggered Fixing:** Secure the beam to each King Post using two 75mm Coated Green Screws (FIX 2).

**Important Screw Placement Tip:** To prevent the hardware from colliding inside the timber, stagger the screws on either side of the joint. Drive one screw through the top side of the joint, and the second screw lower down on the opposite side.

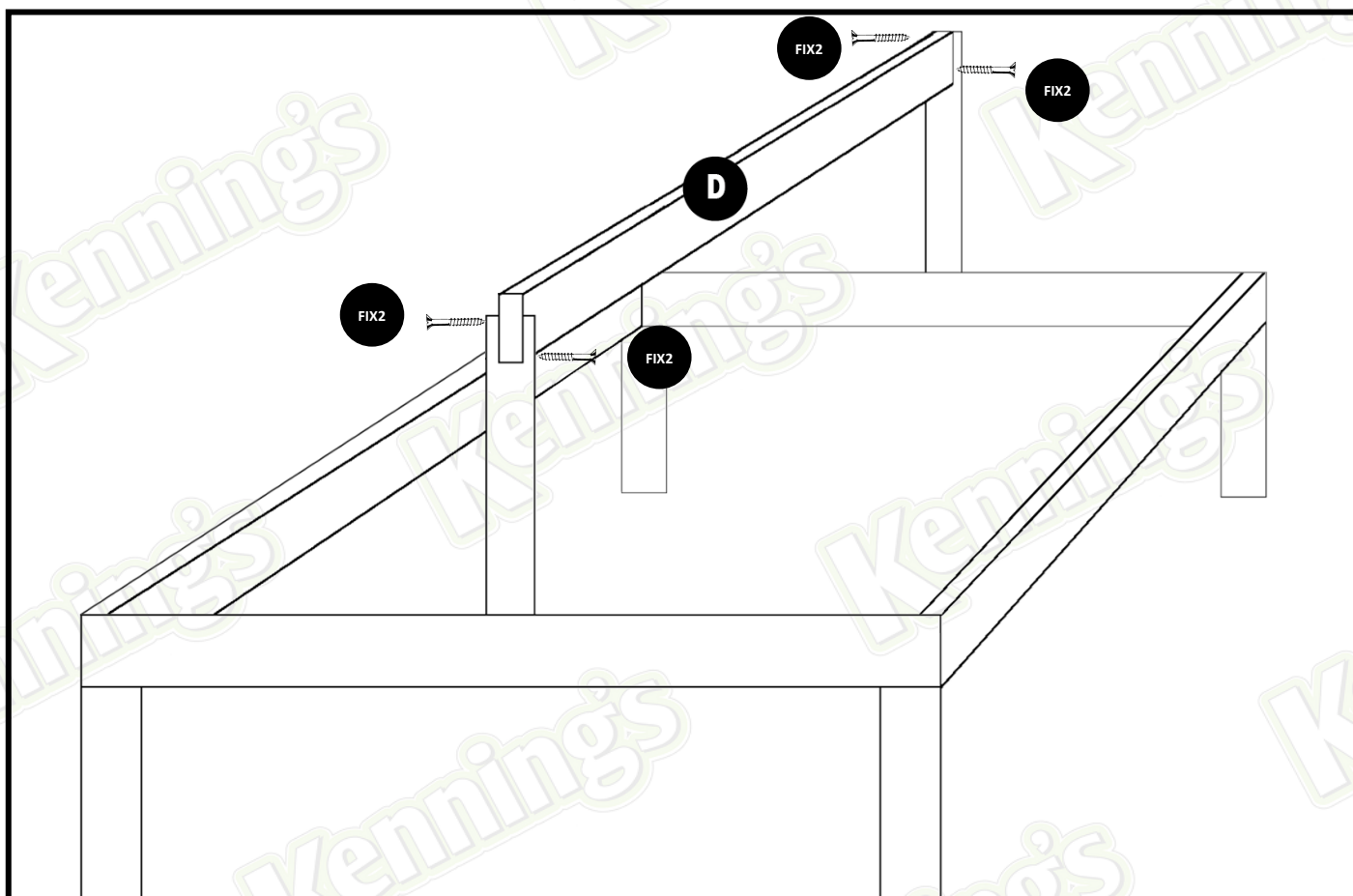

All images are for illustration only. Please see individual item listings for actual item specifications.

Page 9 of 14

# Atlas Meridian Gazebo (All Sizes)



## Step 7

*\*To prevent splits, drill a pilot hole before driving screws\**

### Installing the Roof Rafters

In this step, you will install the rafters to complete the main roof structure. Setting the perimeter rafters first ensures the correct pitch and spacing for the remaining roof timbers.

### Components & Hardware Required

Roof Rafters (Quantity varies by kit size) **(F)**, 100mm Wood Screws **(FIX 3)**

### Phase 1: Installing the Outer (Front & Rear) Rafters

**Alignment:** Begin by positioning the front two and rear two rafters first. These rafters must sit directly flush against the sides of the King Posts **(E)**, running from the Apex Ridge Beam **(D)** down to the main outer frame.

**Fixing the Top:** Secure the top of each rafter by driving a 100mm Wood Screw **(FIX 3)** straight down through the top face of the rafter and directly into the Apex Ridge Beam.

**Fixing the Bottom:** Secure the lower end of the rafter by driving another **(FIX 3)** screw down through the rafter into the horizontal perimeter frame timber below.

### Phase 2: Spacing and Installing the Remaining Rafters

**Setting the Layout:** Use the newly installed front and rear rafters as your boundary lines to lay out the remaining internal rafters.

**Measuring the Intervals:** Measure and mark the positions for the remaining rafters along the apex beam and the lower frame.

Standard spacing is approximately 550mm from centre-to-centre, but please verify with a tape measure to ensure even, symmetrical intervals across your specific model size.

**Final Securing:** Position the remaining Rafters **(F)** on your marks and repeat the fixing process using two 100mm Wood Screws **(FIX 3)** per rafter (one at the top apex, one at the bottom frame).

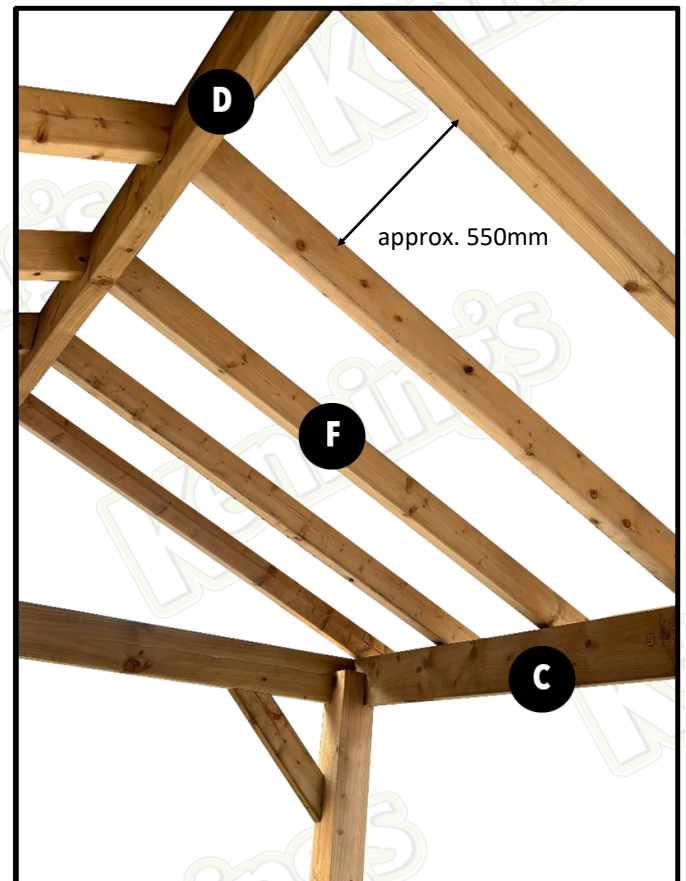

All images are for illustration only. Please see individual item listings for actual item specifications.

# Atlas Meridian Gazebo (All Sizes)

# Kennings's

## Step 8

*\*To prevent splits, drill a pilot hole before driving screws\**

### Installing the Featheredge Roof Boarding

In this stage, you will clad the roof using the featheredge boarding. Working from the bottom upward ensures that rain will naturally shed off the overlapping boards.

### Components & Hardware Required

Featheredge Roof Boards (Quantity varies by kit size) **(H)**, 50mm Coated Green Screws (one screw per board, per rafter) **(FIX 1)**

Start at the lowest point (the eave) of the roof frame. Place the first Featheredge Roof Board **(H)** horizontally across the bottom of the rafters. Ensure the bottom edge and the outer ends sit completely flush with the edges of the Rafters **(F)**.

**Securing the Board:** Fasten the board into place using one 50mm Green Coated Screw **(FIX 1)** at every point where the board crosses a rafter (truss), doing this will not only secure the boards but also prevent warping.

**Working Upward (The Overlap):** Place the next board directly above the first, ensuring you leave a 20mm overlap over the board below.

**Completion:** Repeat this process, maintaining the strict 20mm overlap and securing through the thick edge at each rafter, until you reach the apex, the last board should sit flush with the Apex Beam **(D)**, any gap will be covered in the next step with the Roof Capping **(I)**. Repeat the entire procedure for the opposite side of the roof.



All images are for illustration only. Please see individual item listings for actual item specifications.

Page 11 of 14

# Atlas Meridian Gazebo (All Sizes)

**Kennings**

## Step 9

*\*To prevent splits, drill a pilot hole before driving screws\**

### Installing the Roof Capping

The final step on the roof is to install the ridge capping. This component seals the peak of the roof, closing any remaining gaps between the featheredge boards to ensure the structure is fully weatherproof.

### Components & Hardware Required

Roof Capping (**I**), 50mm Coated Green Screws (**FIX 1**)

**Alignment:** Place the Roof Ridge Capping (**I**) centrally over the peak of the roof, bridging the gap where the two sides of featheredge boarding come together at the top of the roof.

**Positioning:** Adjust the capping so it sits perfectly central and runs completely flush with both the front and rear outer edges of the roof structure.

**Securing:** Fix the capping into position by driving 50mm Green Coated Screws (**FIX 1**) down through the exact centre line of the capping board, securing it directly into the Apex Ridge Beam (**D**) running underneath. Space the screws evenly along the length of the capping to ensure a tight, uniform seal against the elements.

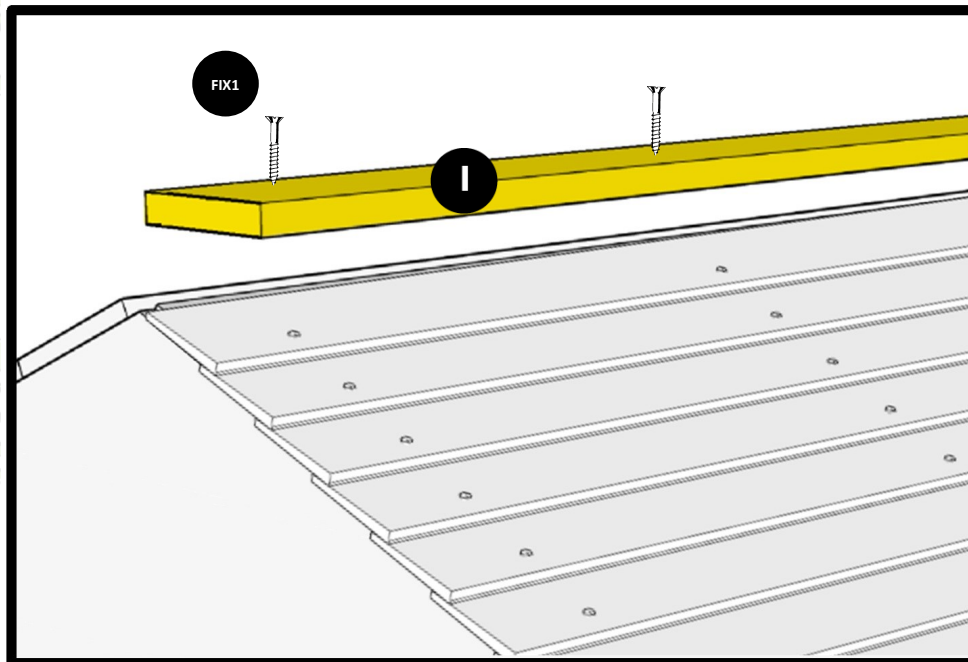

All images are for illustration only. Please see individual item listings for actual item specifications.

Page 12 of 14

# Atlas Meridian Gazebo (All Sizes)

**Kennings**

## Step 10

*\*To prevent splits, drill a pilot hole before driving screws\**

### Installing the Decorative Finial

To complete your gazebo build, you will install the decorative finial to the front of the structure. This cleans up the front fascia by seamlessly covering the joint where the apex ridge beam locks into the front king post.

### Components & Hardware Required

Decorative Finial (**K**), 50mm Coated Green Screws (**FIX 1**)

**Positioning:** Place the Decorative Finial (**K**) over the front face of the joint where the Apex Ridge Beam (**D**) meets the front King Post (**E**).

**Alignment:** Centre the finial horizontally and vertically over the intersection, ensuring it sits entirely straight and level to give the front of your gazebo a clean, symmetrical appearance.

**Securing:** Fix the finial into place by driving one 50mm Green Coated Screw (**FIX 1**) right through the centre of the cap and securely into the timber behind it.



**Congratulations! Your gazebo assembly is now complete.**

**Final Checks:** Give the entire structure a final walkthrough to ensure all screws are tight and flush.

All images are for illustration only. Please see individual item listings for actual item specifications.

Page 13 of 14

# Atlas Meridian Gazebo (All Sizes)

**Kennings**



**Enjoy your new Atlas Meridian Gazebo**

All images are for illustration only. Please see individual item listings for actual item specifications.

Page 14 of 14

[www.Kennings.co.uk](http://www.Kennings.co.uk)